

WiMOD - iM221A

Datasheet Version V2.0

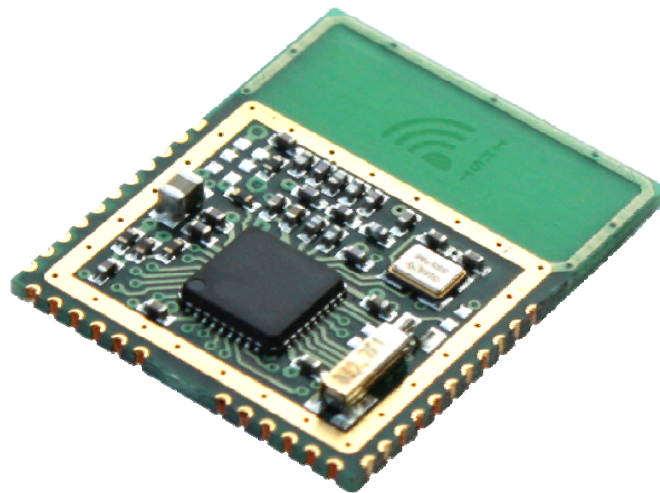

Document ID: 4100/6404/0020

IMST GmbH

Carl-Friedrich-Gauss-Str. 2

D-47475 Kamp-Lintfort



Document Information

File name	iM221A_datasheet
Created	2009-04-17
Total pages	24

Revision History

Version	Description
1.0	Released version.
1.1	Updated Table 5-1 and added Table 5-3.
1.2	Added information concerning POR functionality and RESET input pin
1.3	Updated Table 3-1 (temperature range).
1.4	Updated Table 3-5 (changed DIO_5 ground connection to DIO).
1.5	Updated Chapter 3: - Added/changed information concerning UART, ADC, and Reset. - Updated Table 3-5 (pinout description) - Added information regarding the bootloader. Updated Figure 4-1
2.0	Modifications to document format and layout. Added chapter 4.3, 6, 8, and 9.

Aim of this Document

The aim of this document is to give a detailed product description including interfaces, features and performance of the radio module iM221A.

Table of Contents

1	SUMMARY / INTRODUCTION	5
1.1	Key Features	5
1.2	Applications	5
2	MODULE OVERVIEW	6
3	SPECIFICATION	7
3.1	Absolute Maximum Ratings	7
3.2	General Characteristics	7
3.3	Module Interface Characteristics	8
3.4	RF Characteristics	9
3.5	Pinout Description	10
3.5.1	Pin usage for bootloader functionality	12
3.6	Module Dimension	13
3.7	Recommended Footprint	13
4	INTEGRATION GUIDE	14
4.1	Typical Application Schematic	14
4.2	PCB Design Recommendation	15
4.3	Recommended Soldering Conditions	16
5	GENERAL RADIO SETTINGS	17
5.1	Channel Setup	17
5.2	Power Level Setup	17
5.3	Data Rate Setup	18
6	PACKAGING INFORMATION	19
6.1	Carrier Tape Information	19
6.2	Reel Information	19
7	ORDERING INFORMATION	20
8	APPENDIX	21
8.1	List of Abbreviations	21

8.2	List of Figures	22
8.3	List of Tables	22
8.4	References	22
9	REGULATORY COMPLIANCE INFORMATION	23
10	IMPORTANT NOTICE	24
10.1	Disclaimer	24
10.2	Contact Information	24

1 Summary / Introduction

The iM221A is a compact, low power, bidirectional radio module for the license-free 2.4 GHz Industrial, Science, and Medical (ISM) frequency band. Using the iM221A in an application minimizes the need for an expensive and time-consuming RF development. Fast time to market is possible with this pre-qualified module.

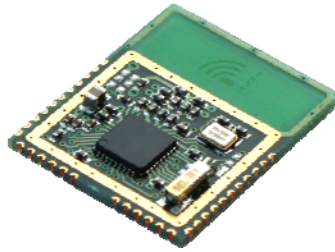

Figure 1-1: iM221A

This datasheet includes the hardware specifications and describes the features of the iM221A as well as the possible RF settings.

1.1 Key Features

- Compact radio module for 2.4 GHz
- Low power consumption, wake on radio (WOR) functionality¹
- 128-bit AES security coprocessor¹
- RF data rate from 2.4 kbps to 250 kbps (500 kbps are available on demand)
- Digital RSSI support
- UART and SPI¹ interface
- Sample applications available
- Bootloading functionality for firmware update
- Solderable like a SMD component
- Integrated antenna or 50 Ohm pad
- Software- and pin-compatible to the iM820A

1.2 Applications

- Security and access systems (wireless locking system)
- Battery driven wireless sensor and actor systems
- Home-, Building-, Industrial Automation
- Remote control
- Metering systems (data logging)
- ...

Please visit our web site www.wireless-solutions.de for more information.

¹ This functionality is not part of the standard firmware and only available on demand. Please read the appropriate firmware documentation for more information about the currently implemented functionalities.

2 Module Overview

The iM221A is a small radio module for the 2.4 GHz ISM band. It provides a complete RF/MCU design including a transceiver, a microcontroller with AES coprocessor, a PCB antenna, and all necessary passive components as depicted in Figure 2-1. The iM221A has several application interfaces². For a serial communication it provides the serial interfaces UART and SPI. Furthermore it offers 9 digital I/Os (if not using SPI) and 8 GPIOs (only 6 when using the UART). All of them can be used as digital input/output and have external interrupt capability. Additionally the GPIOs can be used as input for the 8-channel ADC.

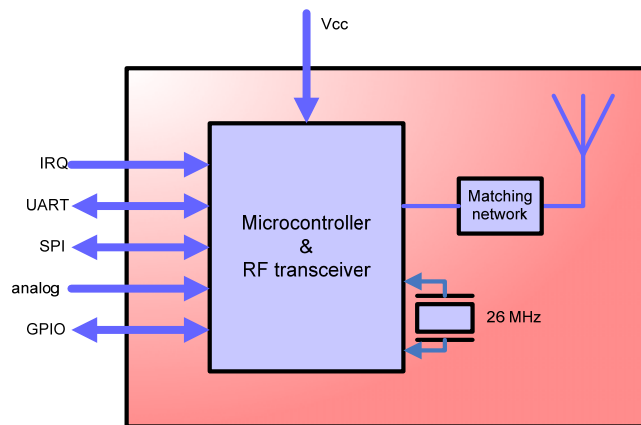

Figure 2-1: Block Diagram - iM221A

The module has a 128-bit AES security coprocessor supported in hardware. This allows encryption and decryption of data using the AES algorithm (128-bit keys) with minimal CPU usage. For low power consumption the module supports the capability to periodically wake up from sleep mode to listen for incoming RF packets. The RF data rate of the module is adjustable up to 250 kbps (GFSK). Decreasing the data rate will increase the sensitivity which results in a longer RF range. To evaluate the radio link quality the iM221A supports a digital RSSI.

Integrated bootloading functionality enables the user to upgrade the firmware over the UART interface. More information about the bootloader and its usage can be found in chapter 3.5.1.

The module is solderable like a SMD-component and can easily be mounted on a simple carrier board with a minimum of required external connections. It is RoHS compliant and pre-qualified in accordance to ETSI EN 300 440-2 V1.4.1.

The wide range of capabilities provided by the iM221A can be tested by using our Demo Board (part of the WiMOD Starter Kit) together with several sample applications.

² Not all can be used at the same time.

3 Specification

In the following different electrical characteristics of the iM221A are listed. Furthermore details and other parameter ranges are available on request.

3.1 Absolute Maximum Ratings

Parameter	Range	Unit	Condition
Supply voltage	-0.3 to VCC +0.3	V	Voltage with respect to GND
Input voltage	-0.3 to VCC +0.3	V	Digital pins.
	0 to VCC-0.2	V	Analog pins
DC current	4	mA	Per digital pin
	20	mA	Only radio module pin 14 and pin 15
Input RF level	+10	dBm	
Operating temperature	-20 to +70	°C	
Storage temperature	+5 to +35	°C	Device not programmed

Table 3-1: Absolute Maximum Ratings

Note: Stress exceeding of one or more of the limiting values listed under “Absolute Maximum Ratings” may cause permanent damage to the radio module.

3.2 General Characteristics

T = 25°C, VDD = 3V (typ.) if nothing else stated

Parameter	Range	Unit	Condition
Operating supply voltage VCC	2.3 to 3.6	V	Typ. 3.0 V
Current consumption	typ. 23	mA	Receive
	typ. 26	mA	Transmit @ 0 dBm
	typ. 5	mA	μC active, TRX off
	typ. 1	μA	Power down
Dimension (L x W x H)	20 x 25 x 2.7	mm	±0.2mm
MCU operation frequency	26	MHz	
Real time oscillator frequency	32.768	kHz	
Memory (Flash)	32	KB	Minimum endurance: 1000 write/erase cycles
Memory (RAM)	4	KB	

Table 3-2: General Characteristics

3.3 Module Interface Characteristics

T = 25°C, VDD = 3V (typ.) if nothing else stated

Parameter	Range	Unit	Condition
Digital output voltage	VCC-0.25 to VCC	V	High level
	GND to 0.3	V	Low level
Digital input voltage	0.7 x VCC to VCC	V	High level
	GND to 0.3 x VCC	V	Low level
I/O pin pull-up/pull-down resistor	20	kΩ	
Pulse width on /RESET pin	min. 250	ns	Low active pin. See Note 1.
Power-On-Reset (POR) threshold	1.5	V	Rising edge
	0.9	V	Falling edge
UART baud rate	typ. 38.4	kbps	Further data rates are available on demand.
SPI baud rate	max. 3250	kbps	
ADC resolution	7 to 12	Bit	
ADC conversion time	20 to 132	μs	Depends on ADC resolution (68 μs @ 10 bit resolution)
ADC input resistance	197	kΩ	
Analog int. reference voltage (Vref)	1.25	V	
Analog input voltage	GND to Vref	V	
Notes:			
1) Shorter pulses may be recognized but will not lead to complete reset of all units within the module.			

Table 3-3: Module Interface Characteristics

Note: Additional to the reset pin the module has a Power-On-Reset (POR) functionality which holds the module in reset state until supply voltage increase above the POR threshold (rising edge). It will not work unless VCC has been below POR threshold (falling edge). See chapter 3.5 for additional information to the POR feature.

All radio module IOs except DIO_7 and DIO_8 are configured as input with pull-up resistor when a reset condition becomes active.

3.4 RF Characteristics

T = 25°C, VDD = 3V (typ.) if nothing else stated

Parameter	Range	Unit	Condition
Frequency range	2401 to 2482	MHz	See 5.1 for current possible RF channels
Channel spacing	1	MHz	See 5.1 for current possible RF channels Other channel spacing is available on request.
RF data rate	up to 250	kbps	See 5.3 for current possible data rates.
	up to 500	kbps	Only with 2-FSK; currently not supported
RF output power	max. 0	dBm	
RF output power range	30	dB	See 0 for possible power level.
RF sensitivity (PCB antenna / 50Ω)	typ. -101	dBm	2.4 kbps data rate / 1 % PER (Note 1)
	typ. -88	dBm	250 kbps data rate / 1 % PER (Note 1)
Modulation techniques	GFSK, 2-FSK		
Range	Up to 500	m	Outdoor (line of sight) with external antenna (0 dBi) on pin ANT.
Notes:			
1) PER = Packet Error Rate ; 20 bytes packet length.			

Table 3-4: RF Characteristics

3.5 Pinout Description

Figure 3-1 depicts the pinout of the iM221A. Its use depends on the programmed firmware.

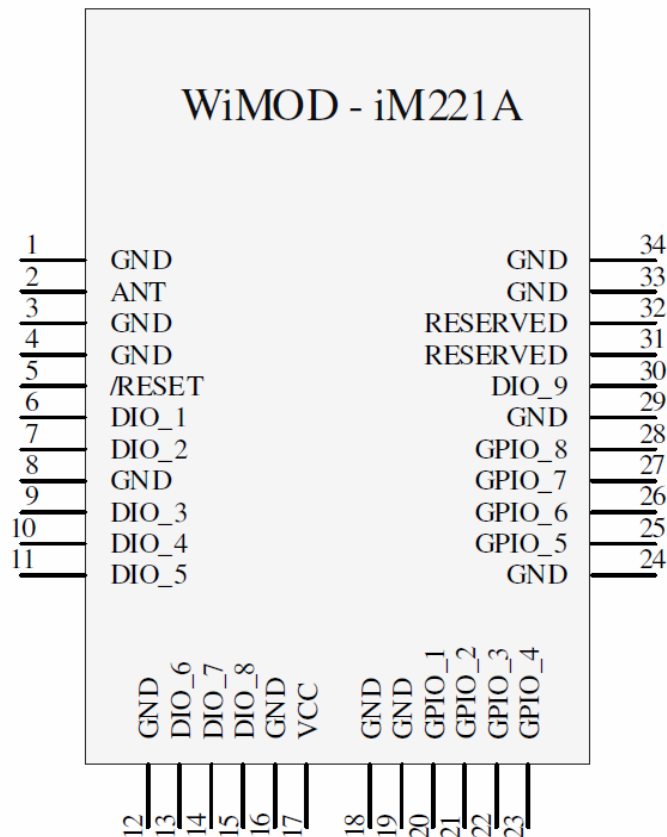

Figure 3-1: Pinout

Most of the pins can be used as digital IO or for some alternate functions (UART, ADC, ...) as described in Table 3-5.

Note: The POR functionality does not work correctly if the I/O-pins are connected to a second power supply while the radio module is powered up.

For example, if connecting the radio module to a host controller (e.g. RXD and TXD to another microcontroller) with separate power supply, it is strictly recommended to set all I/O-pins of this controller to high impedance or to GND potential when the radio module is powered down. If do not so, it is possible that the radio module is powered by the host controller over its I/O-pins with the result that the POR feature does not work correctly and the module status is undefined.

PIN #	PIN Name	Description	PIN Type
1	GND	Ground connection	Supply
2	ANT	Ext. antenna connection. Use only after consultation.	
3	GND	Ground connection	Supply
4	GND	Ground connection	Supply
5	/RESET	Low active RESET input pin	
6	DIO_1	Digital input or output / SPI MISO ^{see Note 1}	IN/OUT
7	DIO_2	Digital input or output / SPI MOSI ^{see Note 1}	IN/OUT
8	GND	Ground connection	Supply
9	DIO_3	Digital input or output / SPI SCK ^{see Note 1}	IN/OUT
10	DIO_4	Digital input or output / SPI SSN ^{see Note 1}	IN/OUT
11	DIO_5	Digital input or output / (Bootloader pin) ^{see Note 2}	IN/OUT
12	GND	Ground connection	Supply
13	DIO_6	Digital input or output	IN/OUT
14	DIO_7	Digital input or output	IN/OUT
15	DIO_8	Digital input or output	IN/OUT
16	GND	Ground connection	Supply
17	VCC	Supply voltage (typ. 3V)	Supply
18	GND	Ground connection	Supply
19	GND	Ground connection	Supply
20	GPIO_1	Digital input or output / analog input	IN/OUT
21	GPIO_2	Digital input or output / analog input / (typical use as status indicator)	IN/OUT
22	GPIO_3	Digital input or output / analog input / UART RXD (UART receive pin)	IN/OUT
23	GPIO_4	Digital input or output / analog input / UART TXD (UART transmit pin)	IN/OUT
24	GND	Ground connection	Supply
25	GPIO_5	Digital input or output / analog input / UART CTS ^{see Note 1}	IN/OUT
26	GPIO_6	Digital input or output / analog input / UART RTS ^{see Note 1}	IN/OUT
27	GPIO_7	Digital input or output / analog input	IN/OUT
28	GPIO_8	Digital input or output / analog input	IN/OUT
29	GND	Ground connection	Supply
30	DIO_9	Digital input or output	IN/OUT
31	Reserved	Internally used. It must be left open.	
32	Reserved	Internally used. It must be left open.	
33	GND	Ground connection	Supply
34	GND	Ground connection	Supply

Notes:

- 1) This functionality is not part of the standard firmware and only available on demand.
- 2) Set this pin to low level during/after a reset to switch into bootloader mode for a firmware update.

Table 3-5: Pinout

All GPIOs can be used as digital input, digital output or analog input pin. Furthermore all digital pins (DIOs and GPIOs) have external interrupt capability which can be used to wake up ^(available on demand) the iM221A. Also all digital pins except DIO_7 and DIO_8 have a pull-up or pull-down capability when configured as input. However DIO_7 and DIO_8 have LED driving capabilities (up to 20mA output current).

The /RESET input pin (pin 5) is very sensitive to noise. For a long reset line it is recommended to add an external low-pass filter (1.0 k Ω and 2.7 nF) close to this pin. Note, that in this case the minimum pulse width to reset the module is longer than stated in Table 3-3.

3.5.1 Pin usage for bootloader functionality

DIO_5 is used as bootloader pin. It has to be set to low level during/after a reset to enter the bootloader for a firmware update over the UART interface (GPIO_3 and GPIO_4). GPIO_2 indicates the status and is set to high level if the bootloader mode is entered and a firmware update is in progress. All not used module IOs except DIO_7 and DIO_8 are configured as input with pull-up resistor in this mode.

To perform a firmware update by a PC, we provide the WiMOD Studio (part of the WiMOD Starter Kit) which contains a simple update tool. Please read the appropriate documentation of the WiMOD Studio for more information about its update functionality.

3.6 Module Dimension

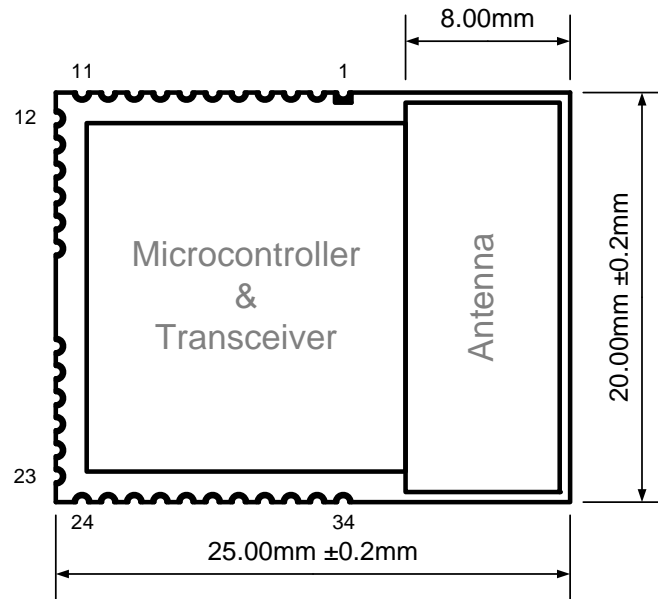

Figure 3-2: Module Dimension

3.7 Recommended Footprint

The pad pitch is 1.27mm.

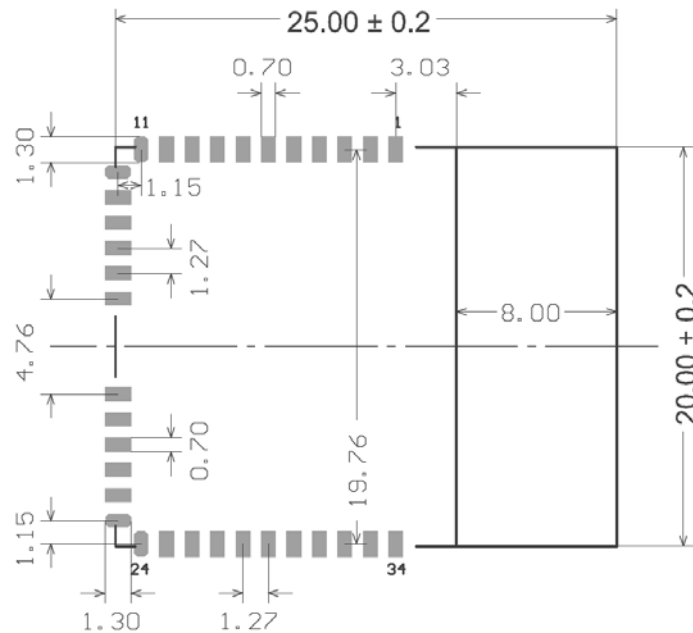

Figure 3-3: Footprint

All dimensions are in millimeters.

4 Integration Guide

4.1 Typical Application Schematic

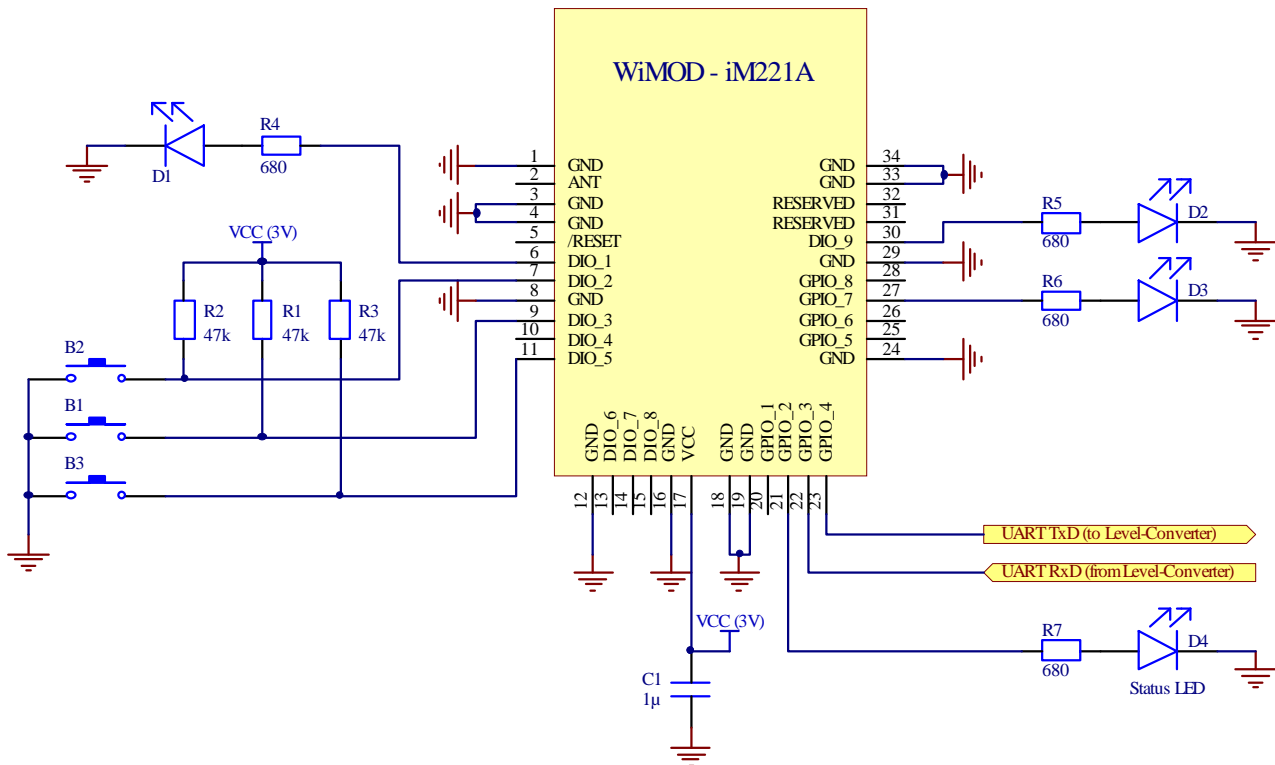

Figure 4-1: Schematic of an Example Application

Figure 4-1 shows a schematic of a typical application (e.g. Starter Kit Application). GPIO_3 and GPIO_4 are used as serial interface and must be connected to a host controller or to a host PC (via a level converter). DIO_1, GPIO_2, GPIO_7, and DIO_9 are used as outputs. It must be ensured that the maximum DC current per output pin is not exceeded. DIO_2, DIO_3 and DIO_5 are used as digital inputs. Therefore B3 can be used to activate the integrated bootloader after a reset. A blocking capacitor is recommended between VCC and GND.

4.2 PCB Design Recommendation

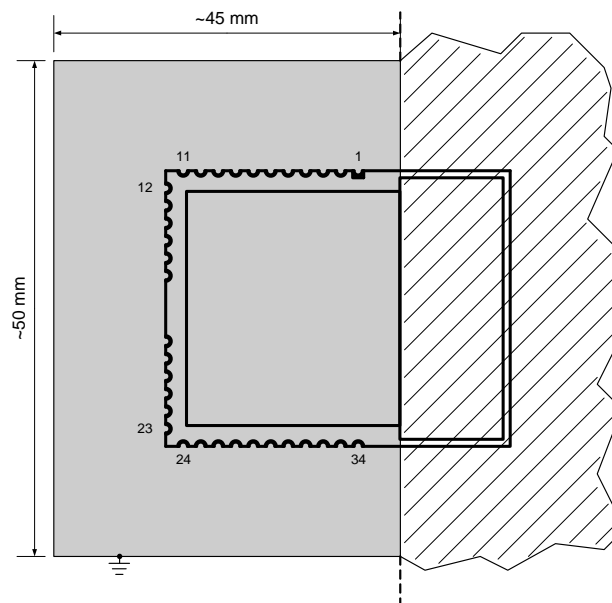

Figure 4-2: Recommended Environment

When designing a carrier board layout for the iM221A the following design considerations are recommended:

- The Top Layer of the carrier board should be kept free of tracks and vias under the iM221A because there are some testpads on the bottom side of the module which are not covered by solder resist.
- As shown in Figure 4-2, the solid grey area must be a ground-plane on the Bottom Layer (or Layer 2 in a multi-layer structure) of the carrier board. Antenna matching and all other measurements were done with these dimensions.

Info: Other dimensions can affect the RF performance respective RF output power, sensitivity, and unwanted emissions. Maybe the matching network of the integrated PCB antenna must be renewed.

- All radio module ground pads must be directly connected to the ground-plane by vias next to each ground pad.
- The hatched area shown in Figure 4-2 has to be free of material (e.g. PCB, metal, housing). If possible, the distance from the antenna area to any material should be at least $\lambda/2$ ^{see 3}.

³ At 2.4 GHz it is approximately 62.5 mm.

4.3 Recommended Soldering Conditions

An example of the temperature profile for the reflow soldering process of the iM221A is depicted in Figure 4-3 with the corresponding values as given by Table 4-1. The temperature values should not exceed the limits.

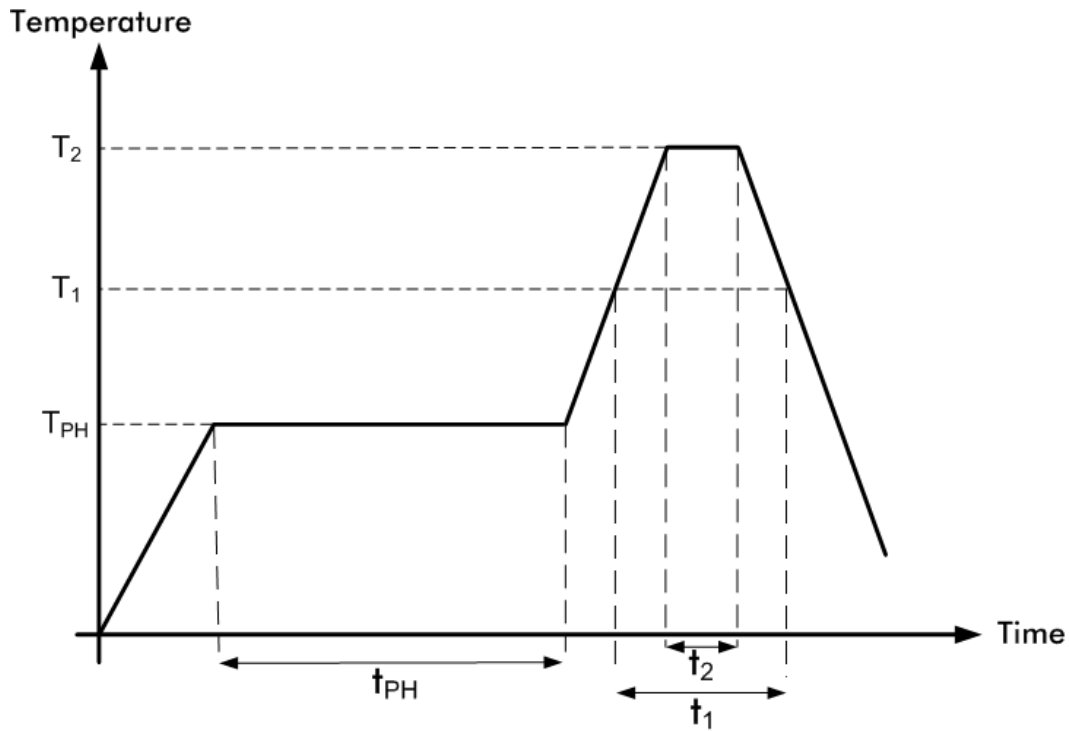

Figure 4-3: Recommended Solder Reflow Profile

Phase	Pb-Free Conditions
Preheating	$t_{PH} = 120s$ $T_{PH} = 160\sim 180^{\circ}C$
Primary heat	$t_1 = 60s$ $T_1 = 220^{\circ}C$
Peak	$t_2 = 10s \text{ (max)}$ $T_2 = 255^{\circ}C$

Table 4-1: Recommended Soldering Parameter for Temperature and Timing

Note: The quality of the soldering process depends on several parameters, e.g. soldering paste, carrier board design, fabrication equipment,...

5 General Radio Settings

In this chapter the possible radio configurations of the iM221A are described. How to configure these settings when using our sample applications is described in the appropriate user guide.

5.1 Channel Setup

Table 5-1 shows the possible RF channel setup.

Channel	Frequency	Unit	Description
0	2401	MHz	Lowest channel
1	2402	MHz	
...			1 MHz channel spacing
80	2481	MHz	
81 (MAX_CH)	2482	MHz	Highest channel

Table 5-1: Possible Frequency Channel Settings

Note: It is recommended to avoid RF frequencies (RF channels) 2405 MHz (4), 2418 MHz (17), 2431 MHz (30), 2444 MHz (43), 2457 MHz (56), and 2470 MHz (69) because the radio transceiver cause some spurious at this frequencies.

5.2 Power Level Setup

Table 5-2 shows the possible power level setup relating to the 50Ω connector (pin ANT).

Power Level	TX power	Unit	Description
0	-30	dBm	Minimum output power
1	-20	dBm	
2	-10	dBm	
3	-6	dBm	
4 (MAX_PWR)	0	dBm	Maximum output power

Table 5-2: Possible Output Power Settings

5.3 Data Rate Setup

Table 5-3 shows the possible RF data rates.

Value	RF data rate	Unit	Description
0	2.4	kbps	Lowest data rate
1	38.4	kbps	
2 (MAX_DR)	250	kbps	Highest data rate

Table 5-3: Possible RF Data Rates

7 Ordering Information

Ordering Part Number	Description	Distributor
iM221A	Radio Module iM221A	tekmodul GmbH wimod@tekmodul.de
SK – iM221A	Starter Kit for the iM221A. See Notes.	tekmodul GmbH wimod@tekmodul.de
AB – iM221A	2x Adapter Board with iM221A	tekmodul GmbH wimod@tekmodul.de

Notes:
The Starter Kit contains two Demo Boards, two Adapter Boards with iM221A, two antennas, and a CD or USB memory stick with sample applications and documentation.

Table 7-1: Ordering Information

For orders, please contact our distributor.

8 Appendix

8.1 List of Abbreviations

AB	= Adapter Board
ADC	= Analog-to-Digital Converter
AES	= Advanced Encryption Standard
DIO	= Digital Input/Output
E.I.R.P.	= Equivalent Isotropic Radiated Power
GFSK	= Gaussian Frequency Shift Keying
GPIO	= General Purpose Input/Output
MCU	= Microcontroller Unit
PCB	= Printed Circuit Board
PER	= Packet Error Rate
RAM	= Random Access Memory
RF	= Radio Frequency
RSSI	= Received Signal Strength Indication
SPI	= Serial Peripheral Interface
UART	= Universal Asynchronous Receiver/Transmitter
USB	= Universal Serial Bus

8.2 List of Figures

Figure 1-1: iM221A	5
Figure 2-1: Block Diagram - iM221A.....	6
Figure 3-1: Pinout	10
Figure 3-2: Module Dimension.....	13
Figure 3-3: Footprint	13
Figure 4-1: Schematic of an Example Application.....	14
Figure 4-2: Recommended Environment.....	15
Figure 4-3: Recommended Solder Reflow Profile	16
Figure 6-1: Dimensions of the iM221A Carrier Tape	19

8.3 List of Tables

Table 3-1: Absolute Maximum Ratings	7
Table 3-2: General Characteristics	7
Table 3-3: Module Interface Characteristics.....	8
Table 3-4: RF Characteristics.....	9
Table 3-5: Pinout	11
Table 4-1: Recommended Soldering Parameter for Temperature and Timing	16
Table 5-1: Possible Frequency Channel Settings.....	17
Table 5-2: Possible Output Power Settings.....	17
Table 5-3: Possible RF Data Rates.....	18
Table 6-1: Reel Information.....	19
Table 7-1: Ordering Information	20

8.4 References

9 Regulatory Compliance Information

The use of radio frequencies is limited by national regulations. The radio module has been designed to comply with the European Union's R&TTE (Radio & Telecommunications Terminal Equipment) directive 1999/5/EC and can be used free of charge within the European Union. Nevertheless, restrictions in terms of maximum allowed RF power or duty cycle may apply.

The radio module has been designed to be embedded into other products (referred as "final products"). According to the R&TTE directive, the declaration of compliance with essential requirements of the R&TTE directive is within the responsibility of the manufacturer of the final product. A declaration of conformity for the radio module is available from IMST GmbH on request.

The applicable regulation requirements are subject to change. IMST GmbH does not take any responsibility for the correctness and accuracy of the aforementioned information. National laws and regulations, as well as their interpretation can vary with the country. In case of uncertainty, it is recommended to contact either IMST's accredited Test Center or to consult the local authorities of the relevant countries.

10 Important Notice

10.1 Disclaimer

IMST GmbH points out that all information in this document is given on an “as is” basis. No guarantee, neither explicit nor implicit is given for the correctness at the time of publication. IMST GmbH reserves all rights to make corrections, modifications, enhancements, and other changes to its products and services at any time and to discontinue any product or service without prior notice. It is recommended for customers to refer to the latest relevant information before placing orders and to verify that such information is current and complete. All products are sold and delivered subject to “General Terms and Conditions” of IMST GmbH, supplied at the time of order acknowledgment.

IMST GmbH assumes no liability for the use of its products and does not grant any licenses for its patent rights or for any other of its intellectual property rights or third-party rights. It is the customer’s duty to bear responsibility for compliance of systems or units in which products from IMST GmbH are integrated with applicable legal regulations. Customers should provide adequate design and operating safeguards to minimize the risks associated with customer products and applications. The products are not approved for use in life supporting systems or other systems whose malfunction could result in personal injury to the user. Customers using the products within such applications do so at their own risk.

Any reproduction of information in datasheets of IMST GmbH is permissible only if reproduction is without alteration and is accompanied by all given associated warranties, conditions, limitations, and notices. Any resale of IMST GmbH products or services with statements different from or beyond the parameters stated by IMST GmbH for that product/solution or service is not allowed and voids all express and any implied warranties. The limitations on liability in favor of IMST GmbH shall also affect its employees, executive personnel and bodies in the same way. IMST GmbH is not responsible or liable for any such wrong statements.

Copyright © 2009, IMST GmbH

10.2 Contact Information

IMST GmbH

Carl-Friedrich-Gauss-Str. 2
47475 Kamp-Lintfort
Germany

T +49 2842 981 0 E wimod@imst.de
F +49 2842 981 299 I www.wireless-solutions.de