

WiMOD - iM240A

Datasheet Version V2.0

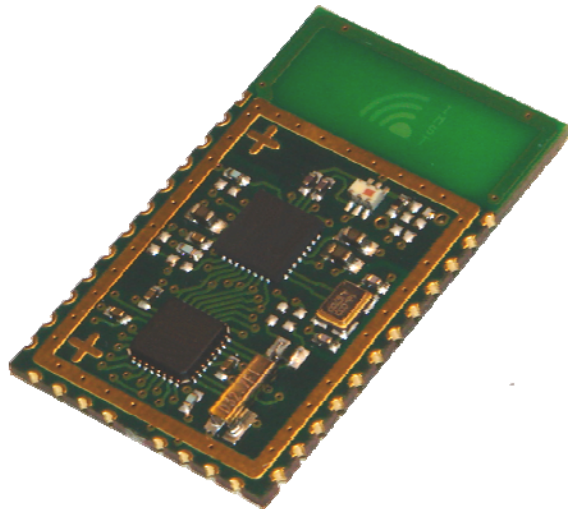

Document ID: 4100/6404/0011

IMST GmbH

Carl-Friedrich-Gauss-Str. 2

D-47475 Kamp-Lintfort



Document Information

File name	iM240A_datasheet
Created	2009-01-15
Total pages	22

Revision History

Version	Description
1.0	Released version.
1.1	Updated Table 7-1
1.2	Added information concerning POR functionality and RESET input pin
1.3	Updated Figure 3-1 and Table 3-5 (pin 26 is now reserved).
1.4	Updated Figure 3-1 and Table 3-5 (pin 29 is now reserved).
1.5	Updated Chapter 3: - Added/changed information concerning UART, ADC, and Reset. - Updated Table 3-5 (pinout description) - Added information regarding the bootloader. Updated Figure 4-1
2.0	Modifications to document format and layout. Added chapter 4.3, 6, 8, and 9.

Aim of this Document

The aim of this document is to give a detailed product description including interfaces, features and performance of the radio module iM240A.

Table of Contents

1	SUMMARY / INTRODUCTION	5
1.1	Key Features	5
1.2	Applications	5
2	MODULE OVERVIEW	6
3	SPECIFICATION	7
3.1	Absolute Maximum Ratings	7
3.2	General Characteristics	7
3.3	Module Interface Characteristics	8
3.4	RF Characteristics	9
3.5	Pinout Description	10
3.5.1	Pin usage for bootloader functionality	12
3.6	Module Dimension	13
3.7	Recommended Footprint	13
4	INTEGRATION GUIDE	14
4.1	Typical Application Schematic	14
4.2	PCB Design Recommendation	15
4.3	Recommended Soldering Conditions	16
5	GENERAL RADIO SETTINGS	17
5.1	Channel Setup	17
5.2	Power Level Setup	17
6	PACKAGING INFORMATION	18
6.1	Carrier Tape Information	18
6.2	Reel Information	18
7	ORDERING INFORMATION	18
8	APPENDIX	19
8.1	List of Abbreviations	19
8.2	List of Figures	20

8.3	List of Tables	20
8.4	References	20
9	REGULATORY COMPLIANCE INFORMATION	21
10	IMPORTANT NOTICE	22
10.1	Disclaimer	22
10.2	Contact Information	22

1 Summary / Introduction

The iM240A is a compact, low power, bidirectional radio module for the license-free 2.4 GHz Industrial, Science, and Medical (ISM) frequency band. Using the iM240A in an application minimizes the need of an expensive and time-consuming RF development. Really fast time to market is possible with this pre-qualified module.

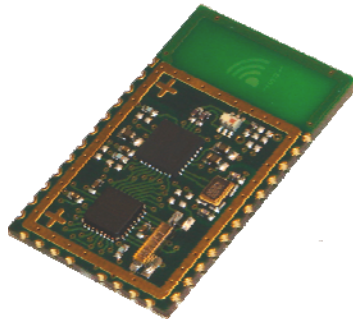

Figure 1-1: iM240A

This datasheet includes the hardware specifications and describes the diverse features of the iM240A as well as the possible RF settings.

1.1 Key Features

- Compact radio module for 2.4 GHz
- Huge link budget (104dB) @ 250kbps
- Output power up to +3 dBm
- Compliant to IEEE 802.15.4
- Digital RSSI support
- 2-wire interface (TWI)¹, compatible to Philips I²C protocol
- UART interface
- Sample applications available
- Bootloading functionality for firmware update
- Solderable like a SMD component
- Integrated antenna or 50 Ohm pad

1.2 Applications

- Wireless networks
- Metering systems
- Home-, building-, industrial automation
- Remote control
- Wireless sensors
- Telemetry
- ...

Please visit our web site www.wireless-solutions.de for more information.

¹ This functionality is not part of the standard firmware and only available on demand. Please read the appropriate firmware documentation for more information about the currently implemented functionalities.

2 Module Overview

The iM240A is a small radio module for the 2.4 GHz ISM band. It contains a complete RF/MCU design including an IEEE 802.15.4 compliant transceiver, a microcontroller with internal RC oscillator, a PCB antenna, and all necessary passive components as depicted in Figure 2-1.

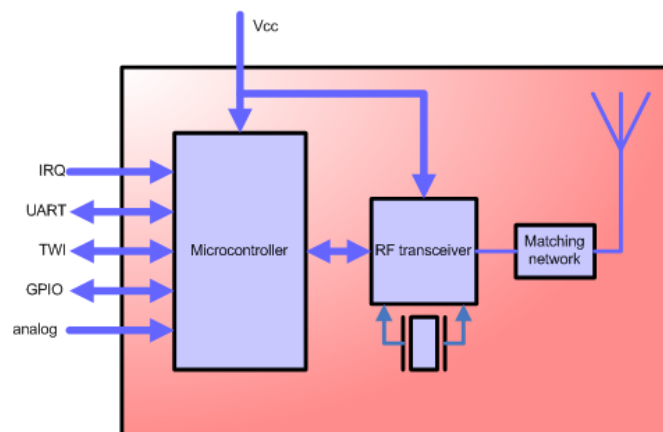

Figure 2-1: Block Diagram - iM240A

The iM240A has several application interfaces². Additionally to a serial UART interface it has a byte-oriented 2-wire interface (TWI) which is compatible to Philips' I²C protocol. Furthermore it offers 3 digital IOs, 2 ADC inputs, and 6 GPIOs (4 GPIOs if using the TWI) which can be used as digital inputs/outputs or as ADC inputs. The ADC resolution is 10 bit. All digital pins are interrupt capable (pin change interrupt) whereas two of them can be external triggered by a (low) level.

The used IEEE 802.15.4 transceiver is high sensitive at 250 kbps resulting in a huge link budget of 104 dB at this data rate. To evaluate the radio link quality the iM240A supports a digital RSSI.

Integrated bootloading functionality enables the user to upgrade the firmware over the UART interface. More information about the bootloader and its usage can be found in chapter 3.5.1.

The module is solderable like a SMD-component and can easily be mounted on a simple carrier board with a minimum of required external connections. It is RoHS compliant and pre qualified in accordance to ETSI EN 300 328.

The wide range of capabilities provided by the iM240A can be tested by using our Demo Board (part of the WiMOD Starter Kit) together with several sample applications.

² Not all can be used at the same time.

3 Specification

3.1 Absolute Maximum Ratings

Parameter	Range	Unit	Condition
Voltage on any pin except /RESET	-0.5 to VCC + 0.5	V	Voltage with respect to GND
Voltage on /RESET	-0.5 to 13	V	Voltage with respect to GND
Input RF level	+10	dBm	
DC current	40	mA	Per IO pin (see Note 1)
	up to 200	mA	On VCC and GND pins
Operating temperature	-20 to +70	°C	
Storage temperature	+15 to +35	°C	
Notes:			
1) The sum of all IO pins should not exceed 100mA.			

Table 3-1: Absolute Maximum Ratings

Note: Stress exceeding of one or more of the limiting values listed under “Absolute Maximum Ratings” may cause permanent damage to the radio module.

3.2 General Characteristics

T = 25°C, VDD = 3V (typ.) if nothing else stated

Parameter	Range	Unit	Condition
Supply voltage	2.0 to 3.6	V	See Note 1
Current consumption	typ. 17	mA	Receive
	typ. 17	mA	Transmit @ 0 dBm
	typ. 20	mA	Transmit @ +3 dBm
	typ. 4	mA	μC active, TRX off
	typ. 18	μA	Power down with BOD enabled
	typ. 1	μA	Power down with BOD disabled
Dimension (L x W x H)	20 x 32.5 x 2.7	mm	
MCU operation frequency	1 or 8	MHz	Typ. 8 MHz; RC oscillator; see Note 2)
Real time oscillator frequency	32.768	kHz	
Memory (Flash)	32	KB	Max. 10000 write/erase cycles
Memory (RAM)	2	KB	
Memory (EEPROM)	1	KB	Max. 100000 write/erase cycles
Notes:			
1) The supply voltage has to be in minimum 2.5 V if the MCU frequency is 8 MHz.			
2) To assure a good accuracy it is necessary to recalibrate the RC oscillator initial after power up, which takes up to 27 ms (without bootloader). If it is necessary to recalibrate it during operation again (for example if the UART is used continuously during temperature variation), it takes up to 280 μs per recalibration.			

Table 3-2: General Characteristics

3.3 Module Interface Characteristics

T = 25°C, VDD = 3V (typ.) if nothing else stated

Parameter	Range	Unit	Condition
Digital output voltage	2.3 to VCC	V	High level; I _{OH} = -10 mA
	GND to 0.6	V	Low level ; I _{OL} = 10 mA
Digital input voltage	0.7 x VCC to VCC + 0.5	V	High level
	-0.5 to 0.3 x VCC	V	Low level
/RESET pin threshold voltage	0.2 x VCC to 0.9 x VCC	V	Low active pin
Pulse width on /RESET pin	min. 2.5	μs	
Power-On-Reset (POR) threshold	1.6	V	Rising edge
	0.6	V	Falling edge
UART baud rate	typ. 38.4	kbps	See Note 1) Further data rates are available on demand.
TWI (2-wire interface) clock	Up to 400	kHz	compatible to Philips' I ² C protocol
ADC resolution	10	Bit	
ADC sample rate	Up to 76.9	ksps	15 ksps @ 10 bit resolution
ADC input resistance	100	MΩ	
Analog int. reference voltage (Vref)	1.0 to 1.2	V	Typ. 1.1 V
Analog ext. reference voltage input (Aref pin).	1 to VCC	V	Currently not supported.
Analog input voltage	GND to Vref	V	
Notes:			
1) If the UART is used continuously at different temperatures, it is necessary to recalibrate the MCU clock during operation, which takes up to 280 μs per recalibration. During this time no UART communication is possible.			

Table 3-3: Module Interface Characteristics

Note: Additional to the reset pin the module has a Power-On-Reset (POR) functionality which holds the module in reset state until supply voltage increase above the POR threshold (rising edge). It will not work unless VCC has been below POR threshold (falling edge). See chapter 3.5 for additional information to the POR feature.

All radio module IOs are tri-stated when a reset condition becomes active.

3.4 RF Characteristics

T = 25°C, VDD = 3V (typ.) if nothing else stated

Parameter	Range	Unit	Condition
Frequency range	2405 to 2480	MHz	See 5.1 for possible RF channels.
Number of channels	16		
Channel spacing	5	MHz	
RF data rate	250	kbps	
RF output power	max. +3	dBm	
RF output power range	20	dB	See 5.2 for possible power level.
RF receiver sensitivity	typ. -101	dBm	PER < 1 % (see Note 1)
Modulation techniques	DSSS with O-QPSK		
Range	Up to 700	m	Outdoor (line of sight)
RSSI sensitivity	-91	dBm	
RSSI resolution	3	dB	
Notes:			
1) PER = Packet Error Rate ; 20 byte packet length			

Table 3-4: RF Characteristics

3.5 Pinout Description

Figure 3-1 depicts the pinout of the iM240A. Its use depends on the programmed firmware.

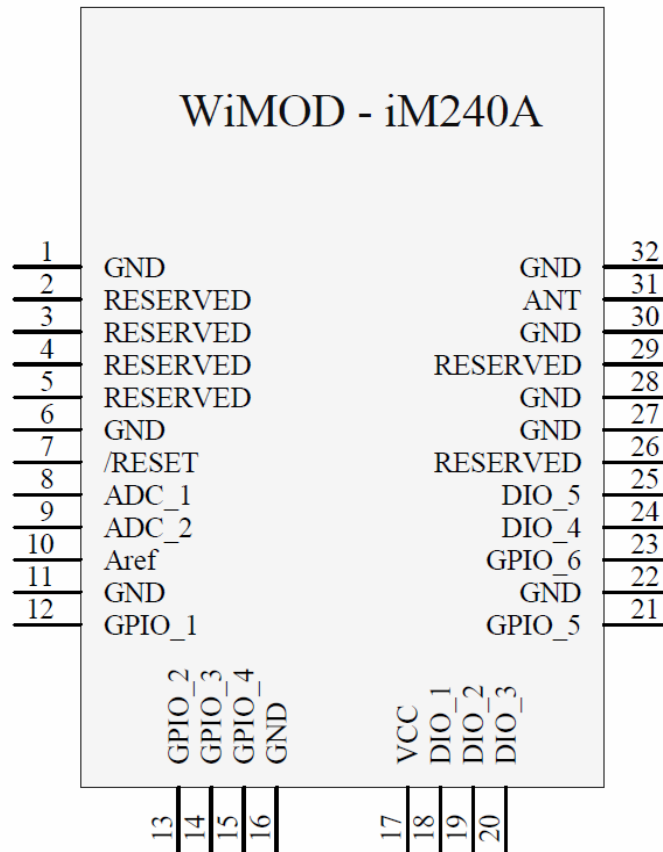

Figure 3-1: Pinout

Pin 8 and 9 can only be used as analog inputs. Most of the other pins can be used as digital IO or for some alternate functions (UART, ADC, Interrupt) as described in Table 3-5.

Note: The POR functionality does not work correctly if the I/O-pins are connected to a second power supply while the radio module is powered up.

For example, if connecting the radio module to a host controller (e.g. RXD and TXD to another microcontroller) with separate power supply, it is strictly recommended to set all I/O-pins of this controller to high impedance or to GND potential when the radio module is powered down. If do not so, it is possible that the radio module is powered by the host controller over its I/O-pins with the result that the POR feature does not work correctly and the module status is undefined.

PIN #	PIN Name	Description	PIN Type
1	GND	Ground connection	Supply
2	Reserved	Internally used. It must be left open.	
3	Reserved	Internally used. It must be left open.	
4	Reserved	Internally used. It must be left open.	
5	Reserved	Internally used. It must be left open.	
6	GND	Ground connection	Supply
7	/RESET	Low active RESET input pin	
8	ADC_1	Analog input pin 1	ANALOG IN
9	ADC_2	Analog input pin 2	ANALOG IN
10	Aref	External reference voltage for ADC	ANALOG REF
11	GND	Ground connection	Supply
12	GPIO_1	Digital input or output / analog input	IN/OUT
13	GPIO_2	Digital input or output / analog input	IN/OUT
14	GPIO_3	Digital input or output / analog input / (Bootloader pin) ^{see Note 2}	IN/OUT
15	GPIO_4	Digital input or output / analog input	IN/OUT
16	GND	Ground connection	Supply
17	VCC	Supply voltage (typ. 3V)	Supply
18	DIO_1	Digital input or output / UART RXD (UART receive pin)	IN/OUT
19	DIO_2	Digital input or output / UART TXD (UART transmit pin)	IN/OUT
20	DIO_3	Digital input or output / INT0 / (typical use as status indicator)	IN/OUT
21	GPIO_5	Digital input or output / analog input / SCL (2-wire serial bus clock) ^{see Note 1}	IN/OUT
22	GND	Ground connection	Supply
23	GPIO_6	Digital input or output / analog input / SDA (2-wire serial bus data) ^{see Note 1}	IN/OUT
24	DIO_4	Digital input or output / ext. INT1 (level interrupt)	IN/OUT
25	DIO_5	Digital input or output	IN/OUT
26	Reserved	Internally used. It must be left open.	
27	GND	Ground connection	Supply
28	GND	Ground connection	Supply
29	Reserved	Internally used. It must be left open.	
30	GND	Ground connection	Supply
31	ANT	Ext. antenna connection. Use only after consultation.	
32	GND	Ground connection	Supply

Notes:

- 1) This functionality is not part of the standard firmware and only available on request.
- 2) Set this pin to low level during/after a reset to switch into bootloader mode for a firmware update.

Table 3-5: Pinout

All GPIOs can be used as digital input, digital output or analog input pin. Furthermore all digital pins have pin change interrupt functionality and can serve as external interrupt source. Additionally DIO_3 and DIO_4 have (low) level interrupt functionality.

3.5.1 Pin usage for bootloader functionality

GPIO_3 is used as bootloader pin. It has to be set to low level during/after a reset to enter the bootloader for a firmware update over the UART interface (DIO_1 and DIO_2). DIO_3 indicates the status and is set to high level if the bootloader mode is entered and a firmware update is in progress. All not used module IOs are tri-stated in this mode.

To perform a firmware update by a PC, we provide the WiMOD Studio (part of the WiMOD Starter Kit) which contains a simple update tool. Please read the appropriate documentation of the WiMOD Studio for more information about its update functionality.

3.6 Module Dimension

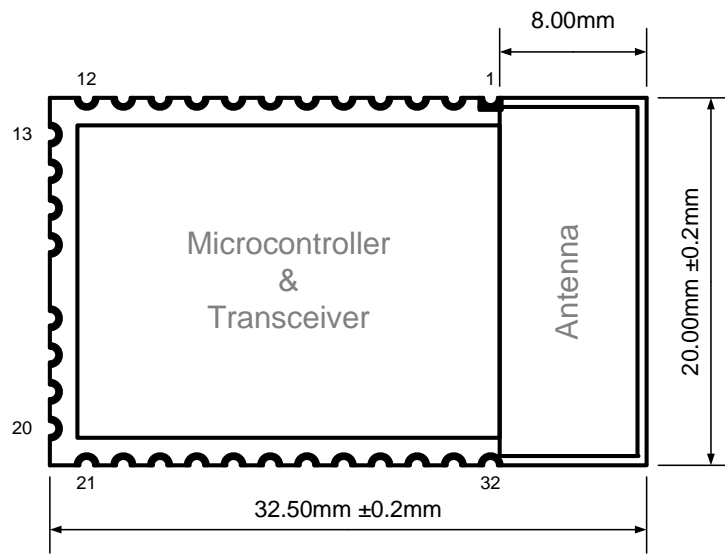

Figure 3-2: Dimension

3.7 Recommended Footprint

The pin pitch is 2.0 mm.

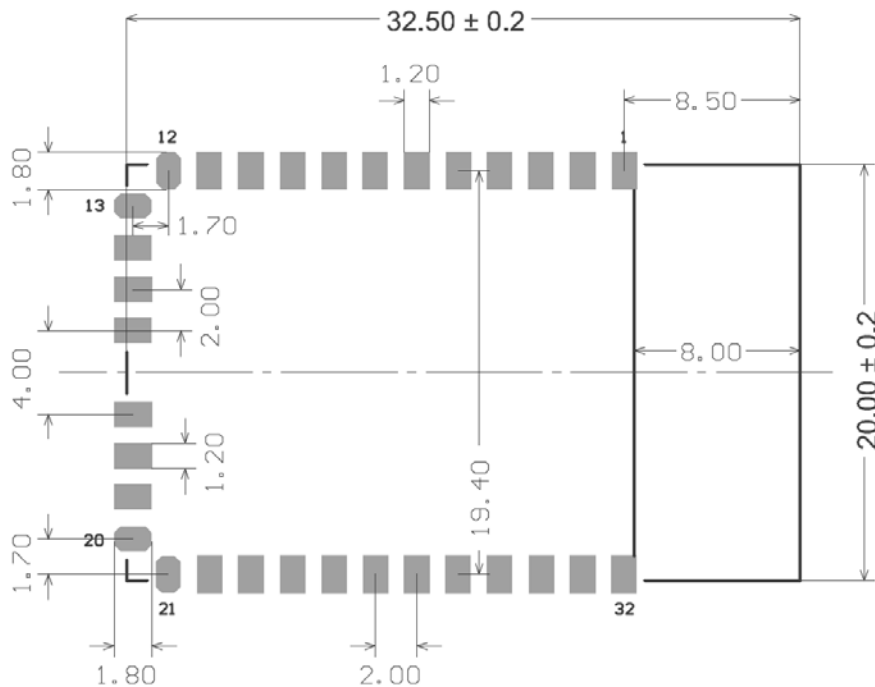

Figure 3-3: Footprint

All dimensions are in millimeters.

4 Integration Guide

4.1 Typical Application Schematic

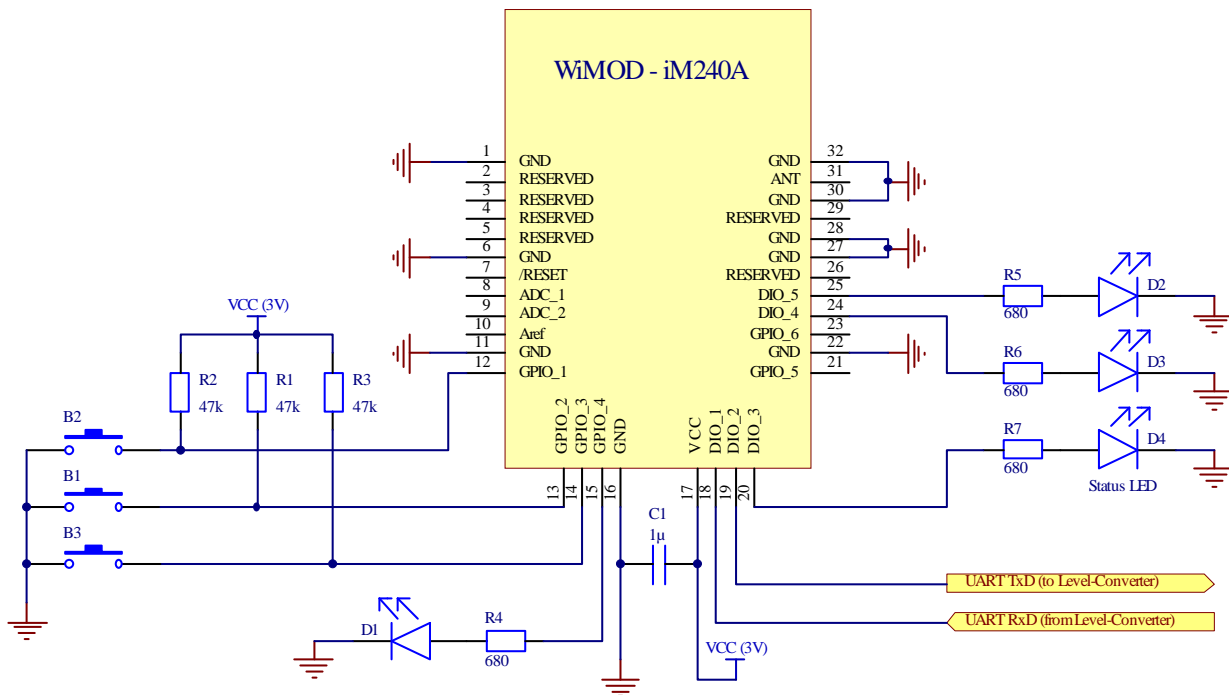

Figure 4-1: Schematic of an Example Application

Figure 4-1 shows a schematic of a typical application (e.g. Starter Kit Application). DIO_1 and DIO_2 are used as serial interface and must be connected to a host controller or to a host PC (via a level converter). GPIO_4, DIO_3, DIO_4, and DIO_5 are used as outputs. It must be ensured that the maximum DC current per output pin (see Table 3-1) is not exceeded. GPIO_1, GPIO_2 and GPIO_3 are used as digital inputs. Therefore B3 can be used to activate the integrated bootloader after a reset. Between VCC and GND a blocking capacitor is recommended.

4.2 PCB Design Recommendation

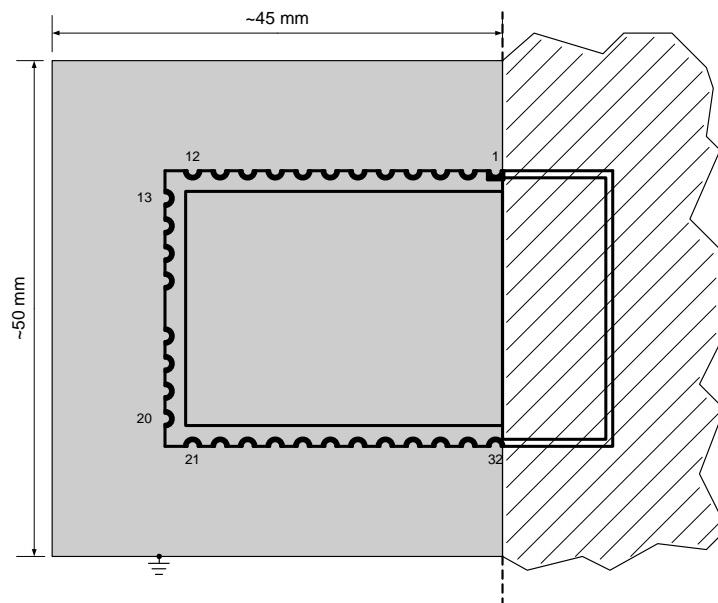

Figure 4-2: Recommended Environment

When designing a carrier board layout for the iM240A the following design considerations are recommended:

- The Top Layer of the carrier board should be kept free of tracks and vias under the iM240A because there are some testpads on the bottom side of the module which are not covered by solder resist.
- As shown in Figure 4-2, the solid grey area must be a ground-plane on the Bottom Layer (or Layer 2 in a multi-layer structure) of the carrier board. Antenna matching and all other measurements were done with these dimensions.

Info: Other dimensions can affect the RF performance respective RF output power, sensitivity, and unwanted emissions. Maybe the matching network of the integrated PCB antenna must be renewed.

- All radio module ground pads must be directly connected to the ground-plane by vias next to each ground pad.
- The hatched area shown in Figure 4-2 has to be free of material (e.g. PCB, metal, housing). If possible, the distance from the antenna area to any material should be at least $\lambda/2$ ^{see 3}.

³ At 2.4 GHz it is approximately 62.5 mm.

4.3 Recommended Soldering Conditions

An example of the temperature profile for the reflow soldering process of the iM240A is depicted in Figure 4-3 with the corresponding values as given by Table 4-1. The temperature values should not exceed the limits.

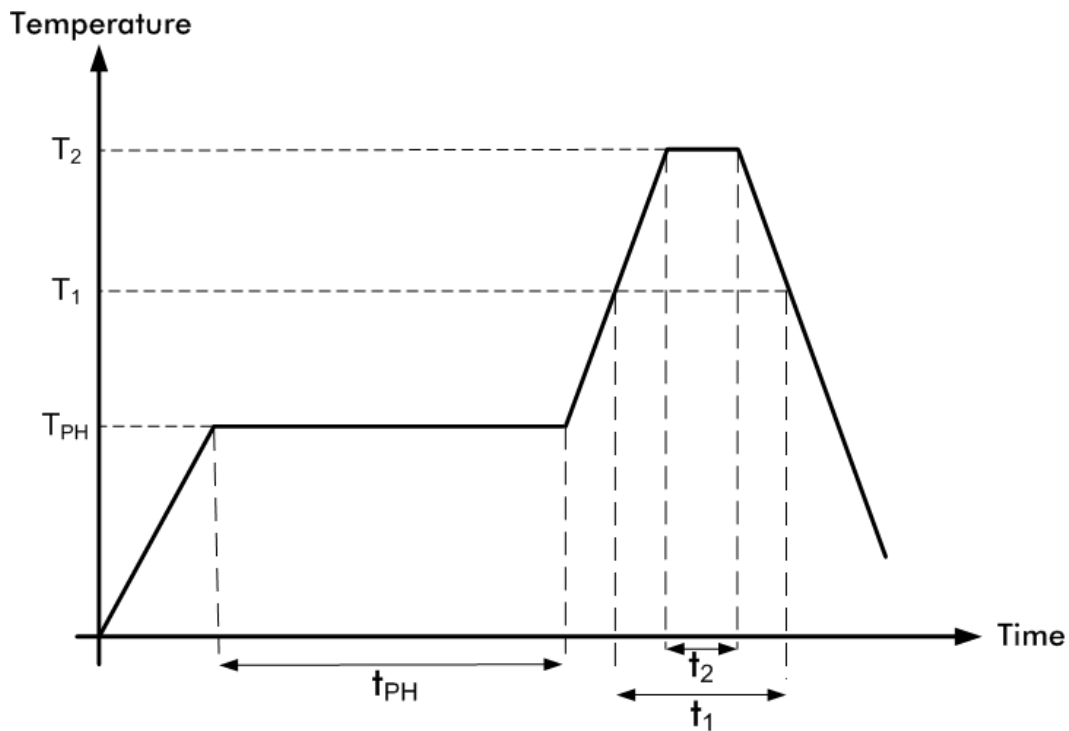

Figure 4-3: Recommended Solder Reflow Profile

Phase	Pb-Free Conditions
Preheating	$t_{PH} = 120s$ $T_{PH} = 160\sim 180^{\circ}C$
Primary heat	$t_1 = 60s$ $T_1 = 220^{\circ}C$
Peak	$t_2 = 10s (max)$ $T_2 = 255^{\circ}C$

Table 4-1: Recommended Soldering Parameter for Temperature and Timing

Note: The quality of the soldering process depends on several parameters, e.g. soldering paste, carrier board design, fabrication equipment,...

5 General Radio Settings

In this chapter the possible radio configurations of the iM240A are described. How to configure these settings when using our sample applications is described in the appropriate user guide of the applications.

5.1 Channel Setup

Table 5-1 shows the RF channel setup.

Channel	Frequency	Unit	Description
11	2405	MHz	Lowest channel
12	2410	MHz	
...	...		5 MHz channel spacing
15	2475	MHz	
26 (MAX_CH)	2480	MHz	Highest channel

Table 5-1: Possible Frequency Channel Settings

5.2 Power Level Setup

Table 5-2 shows the possible power level setup.

Power Level	TX power	Unit	Description
0	-17	dBm	Minimum output power
1	-12	dBm	
2	-9	dBm	
3	-7	dBm	
4	-5	dBm	
5	-4	dBm	
6	-3	dBm	
7	-2	dBm	
8	-1	dBm	
9	0	dBm	
10	+0.5	dBm	
11	+1	dBm	
12	+1.5	dBm	
13	+2	dBm	
14	+2.5	dBm	
15 (MAX_PWR)	+3	dBm	Maximum output power

Table 5-2: Possible Output Power Settings

6 Packaging Information

6.1 Carrier Tape Information

6.2 Reel Information

7 Ordering Information

Ordering Part Number	Description	Distributor
iM240A	Radio Module iM240A	tekmodul GmbH wimod@tekmodul.de
SK – iM240A	Starter Kit for the iM240A. See Notes.	tekmodul GmbH wimod@tekmodul.de
AB – iM240A	2x Adapter Board with iM240A	tekmodul GmbH wimod@tekmodul.de

Notes:
The Starter Kit contains two Demo Boards, two Adapter Boards with iM240A, two antennas, and a CD or USB memory stick with sample applications and documentation.

Table 7-1: Ordering Information

For orders, please contact our distributor.

8 Appendix

8.1 List of Abbreviations

AB	= Adapter Board
ADC	= Analog-to-Digital Converter
BOD	= Brown Out Detection
DIO	= Digital Input/Output
GPIO	= General Purpose Input/Output
IEEE	= Institute of Electrical and Electronics Engineers
I ² C	= Inter-Integrated Circuit
MCU	= Microcontroller Unit
PCB	= Printed Circuit Board
PER	= Packet Error Rate
RAM	= Random Access Memory
RF	= Radio Frequency
RSSI	= Received Signal Strength Indication
SPI	= Serial Peripheral Interface
TWI	= 2-Wire Interface
UART	= Universal Asynchronous Receiver/Transmitter
USB	= Universal Serial Bus

8.2 List of Figures

Figure 1-1: iM240A	5
Figure 2-1: Block Diagram - iM240A.....	6
Figure 3-1: Pinout	10
Figure 3-2: Dimension.....	13
Figure 3-3: Footprint	13
Figure 4-1: Schematic of an Example Application.....	14
Figure 4-2: Recommended Environment.....	15
Figure 4-3: Recommended Solder Reflow Profile	16

8.3 List of Tables

Table 3-1: Absolute Maximum Ratings	7
Table 3-2: General Characteristics	7
Table 3-3: Module Interface Characteristics.....	8
Table 3-4: RF Characteristics.....	9
Table 3-5: Pinout	11
Table 4-1: Recommended Soldering Parameter for Temperature and Timing	16
Table 5-1: Possible Frequency Channel Settings.....	17
Table 5-2: Possible Output Power Settings.....	17
Table 7-1: Ordering Information	18

8.4 References

9 Regulatory Compliance Information

The use of radio frequencies is limited by national regulations. The radio module has been designed to comply with the European Union's R&TTE (Radio & Telecommunications Terminal Equipment) directive 1999/5/EC and can be used free of charge within the European Union. Nevertheless, restrictions in terms of maximum allowed RF power or duty cycle may apply.

The radio module has been designed to be embedded into other products (referred as "final products"). According to the R&TTE directive, the declaration of compliance with essential requirements of the R&TTE directive is within the responsibility of the manufacturer of the final product. A declaration of conformity for the radio module is available from IMST GmbH on request.

The applicable regulation requirements are subject to change. IMST GmbH does not take any responsibility for the correctness and accuracy of the aforementioned information. National laws and regulations, as well as their interpretation can vary with the country. In case of uncertainty, it is recommended to contact either IMST's accredited Test Center or to consult the local authorities of the relevant countries.

10 Important Notice

10.1 Disclaimer

IMST GmbH points out that all information in this document is given on an “as is” basis. No guarantee, neither explicit nor implicit is given for the correctness at the time of publication. IMST GmbH reserves all rights to make corrections, modifications, enhancements, and other changes to its products and services at any time and to discontinue any product or service without prior notice. It is recommended for customers to refer to the latest relevant information before placing orders and to verify that such information is current and complete. All products are sold and delivered subject to “General Terms and Conditions” of IMST GmbH, supplied at the time of order acknowledgment.

IMST GmbH assumes no liability for the use of its products and does not grant any licenses for its patent rights or for any other of its intellectual property rights or third-party rights. It is the customer’s duty to bear responsibility for compliance of systems or units in which products from IMST GmbH are integrated with applicable legal regulations. Customers should provide adequate design and operating safeguards to minimize the risks associated with customer products and applications. The products are not approved for use in life supporting systems or other systems whose malfunction could result in personal injury to the user. Customers using the products within such applications do so at their own risk.

Any reproduction of information in datasheets of IMST GmbH is permissible only if reproduction is without alteration and is accompanied by all given associated warranties, conditions, limitations, and notices. Any resale of IMST GmbH products or services with statements different from or beyond the parameters stated by IMST GmbH for that product/solution or service is not allowed and voids all express and any implied warranties. The limitations on liability in favor of IMST GmbH shall also affect its employees, executive personnel and bodies in the same way. IMST GmbH is not responsible or liable for any such wrong statements.

Copyright © 2009, IMST GmbH

10.2 Contact Information

IMST GmbH

Carl-Friedrich-Gauss-Str. 2
47475 Kamp-Lintfort
Germany

T +49 2842 981 0 E wimod@imst.de
F +49 2842 981 299 I www.wireless-solutions.de